



**610-638-1221**  
**sales@trenchdrain.com**  
 PO BOX 377 - FREMONT, OH 43420

**PROJECT ID:** \_\_\_\_\_  
**CONTRACT NO:** \_\_\_\_\_

**LOCATION:** \_\_\_\_\_

RELEASED: 6.15.21  
 REVISION: A

**FGK-4015-EZ**      **FIBERGLASS KIT WITH I4015 GRATE AND EZ FRAME**

NOMINAL SYSTEM WIDTH	ACTUAL GRATE WIDTH	SYSTEM LENGTH	KIT PART NO.
9"	9.00"	4'	FGK-4015-EZ-0904
		8'	FGK-4015-EZ-0908
		12'	FGK-4015-EZ-0912
		16'	FGK-4015-EZ-0916
		20'	FGK-4015-EZ-0920
12"	12.00"	4'	FGK-4015-EZ-1204
		8'	FGK-4015-EZ-1208
		12'	FGK-4015-EZ-1212
		16'	FGK-4015-EZ-1216
		20'	FGK-4015-EZ-1220
15"	15.00"	4'	FGK-4015-EZ-1504
		8'	FGK-4015-EZ-1508
		12'	FGK-4015-EZ-1512
		16'	FGK-4015-EZ-1516
		20'	FGK-4015-EZ-1520
		40'	FGK-4015-EZ-1540

EXAMPLE OF A TYPICAL INSTALLATION

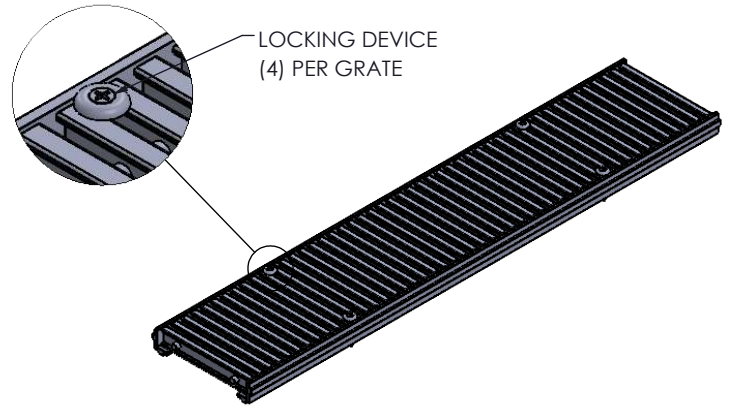
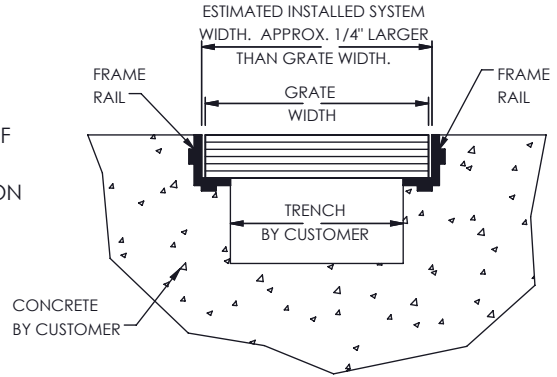

KITS ARE SUPPLIED IN 4FT & 8FT SECTIONS



**DIN APPLICATION LOAD CLASS C:**  
 CURB SIDES, HIGHWAY SHOULDERS AND PARKING AREAS. DESIGNED FOR A DISTRIBUTED PRESSURE OF 56, 200 LBS. (250kN)

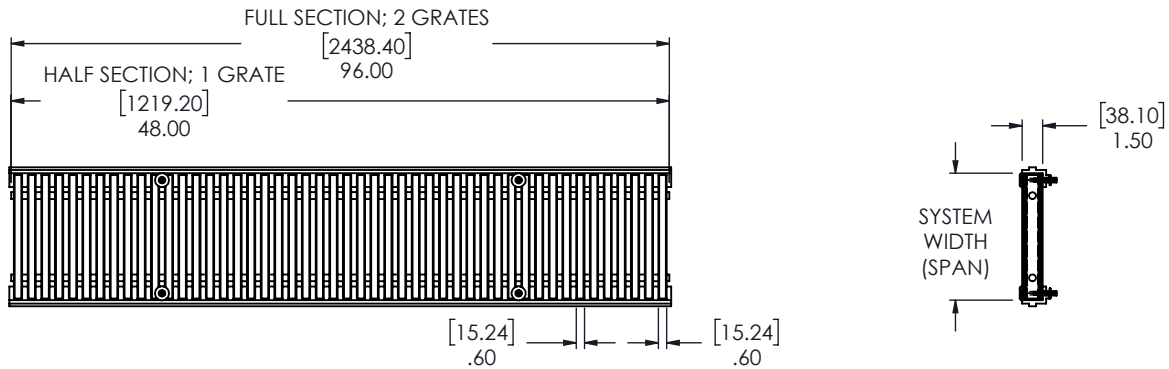

**MANUFACTURER**



**DISCLAIMER** - The customer and the customer's architects, engineers, consultants, and other professionals are completely responsible for the selection installation and maintenance of any product purchased from Trench Drain Systems and/or its manufacturers. TRENCH DRAIN SYSTEMS MAKES NO WARRANTY, EXPRESS OR IMPLIED, AS TO THE SUITABILITY, DESIGN, MERCHANTABILITY, OR FITNESS OF THE PRODUCT FOR CUSTOMERS APPLICATION. The drawing and information provided remain the property and copyright of the manufacturer listed. The manufacturer reserves the right to modify specification without notice.

**ENGINEERING SPECIFICATION**

TDS FIBERGLASS KITS ARE NONCONDUCTIVE, LIGHTWEIGHT SAFE-T-SPAN GRATING MANUFACTURED FROM A FIRE-RETARDANT ISOPHTHALIC POLYESTER RESIN (ISOFR). CORROSION- AND SLIP-RESISTANT MATERIAL REPLACES STEEL BAR GRATING. THE HIGH PERCENTAGE OF GLASS PROVIDES DURABILITY AND HIGH UNIDIRECTIONAL STRENGTH AND STIFFNESS MAKING THIS THE IDEAL PRODUCT FOR APPLICATIONS WHERE LONGER SUPPORT SPANS ARE REQUIRED. SUPPORT LOADS IN THE SPAN DIRECTION ONLY. THE GRATE HAS AN OPEN AREA OF 40% AND IS ADA APPROVED. EACH GRATE MEASURES 1.50" THICK X 48.00" LONG. KIT INCLUDES GRATE(S), LOCKING DEVICES AND FRAME RAILS.